

BAUER
KOMPRESSOREN

Industrial- Compressor- Systems

Air + Nitrogen —

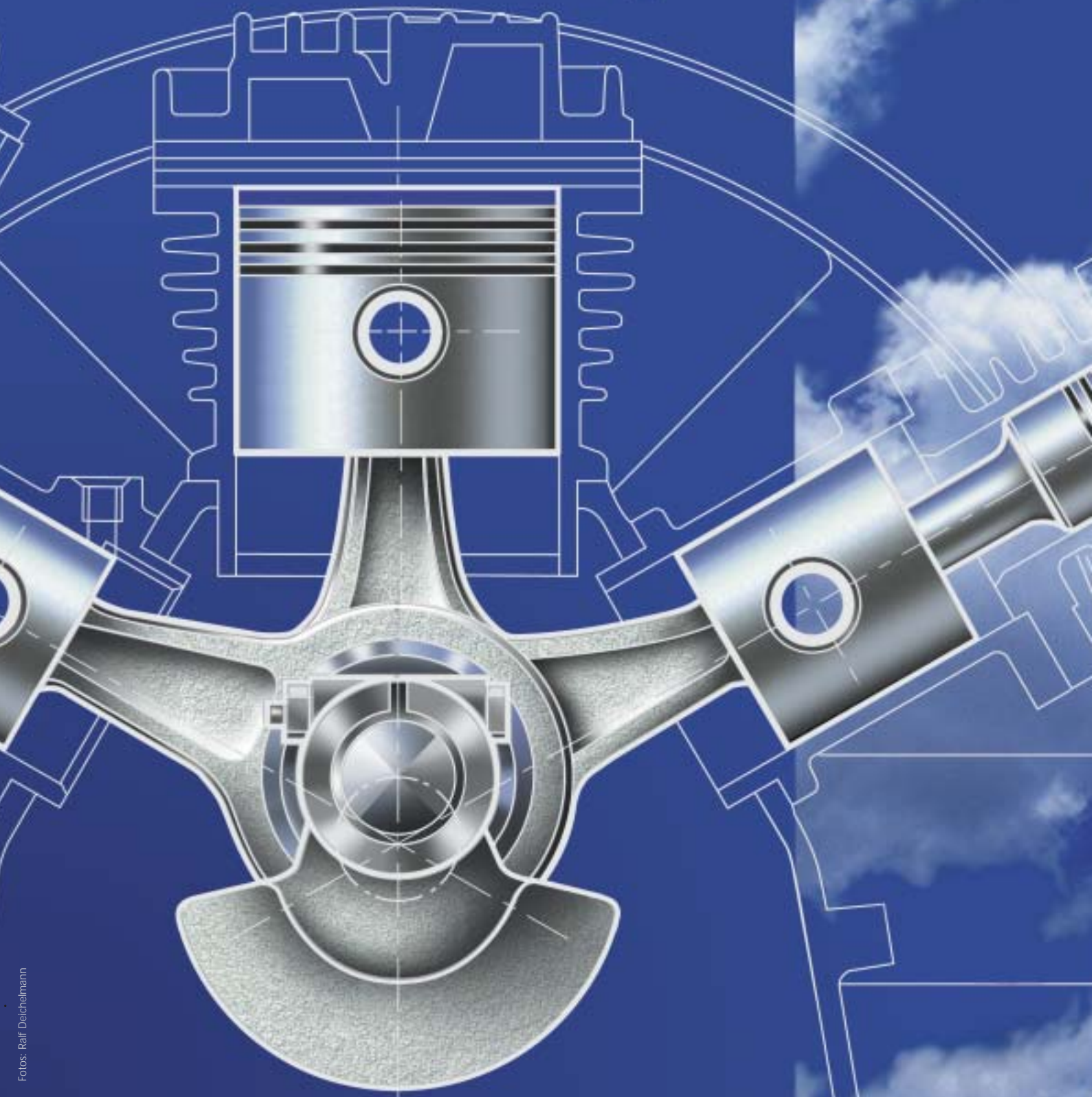

HIGH PRESSURE INTEGRATED SYSTEM TECHNOLOGY

CUSTOM-BUILT FOR SPECIFIC INDUSTRIAL APPLICATIONS

Modern industrial processes require absolute operating safety, flexible unit configuration and investment security.

High Pressure System Technology by **BAUER** enables each customer to tailor the unit **exactly according to their requirements**.

This **process begins** at the **conceptual stage** and in the design and development of the compressor unit. BAUER perceives the **design, development** and **evolution** of its machines as a **partnership between Manufacturer and User**. This philosophy is continuous in the approach to provision of **spare parts, long-term maintenance contracts** and **product support** to ensure every customer a **first class service**.



High Pressure Leakage Testing

Units for **compression**

of air and N₂

Pressure range:
25 to 500 bar

F.A.D.:
6 to 408 m³/h

Design:
Open Configuration or Super Silent (Enclosed)

Systems for **purification**

of air and N₂

P-filter systems

Removal of CO₂ (at intake), Humidity, Oil, CO and Solid Particle contaminants in Air and N₂.

SECCANT

Regenerative Dryer

Made for **continuous operation** and **efficient, economic purification** air and gas.

Air qualities in accordance with **various standards** are achievable:

-**breathing air acc. to**
DIN EN 12021

-**medical air** acc. to European pharmacy

-**purest air** acc. to MILR81202D resp. DEF Std. 58-96

-compressed air acc. to **DIN EN ISO 8573-1**, oil content class 2, particle and humidity class 3

Refrigeration Dryers

Efficient drying of air and gases in the medium pressure range for **effective resistance to corrosion** of piping and components.

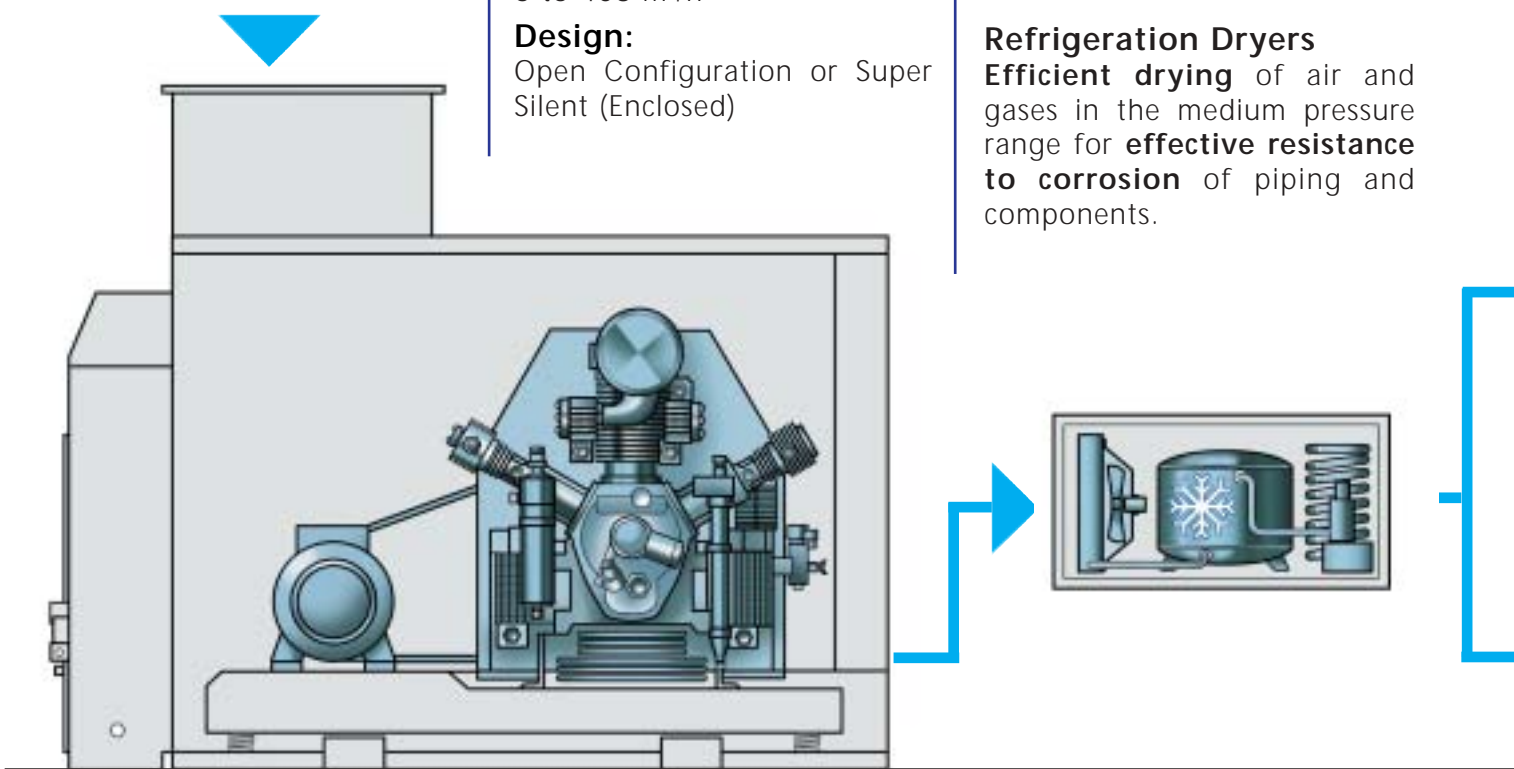



Aircraft components inflation with N₂

Systems for storage

of air and N₂

Storage cylinder systems up to 500 bar with 50 or 80 l water volume *. Units are available as **single unit** or as an extendable **modular system** to provide the required storage capacity. Dependant upon physical limitations, **various configurations can be provided** to optimize the utilization of available space.

*geometric volume

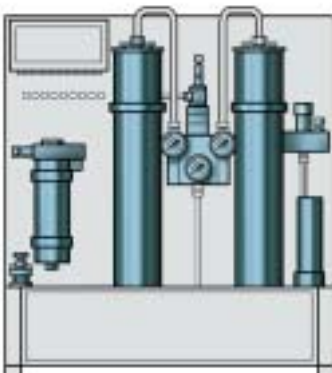
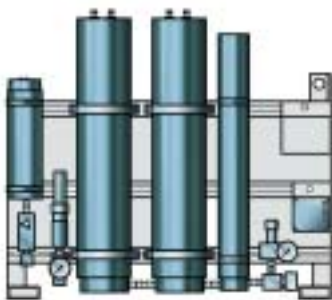

Systems for distribution and dosing

of air and N₂

Switch over device for maximum rate cylinder filling.

Switch on of unit only for topping up of storage cylinders.

Pressure reducing panels: for constant regulation of outlet pressure.

Filling panels for breathing air, industrial air and N₂. Available in a **great variety** of standard configurations to **satisfy every need** with options for switch over device to facilitate two **separate pressure ranges**.

Dosing stations with fully programmable pressure range for testing and/or pressurization of associated equipment.

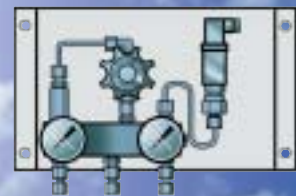
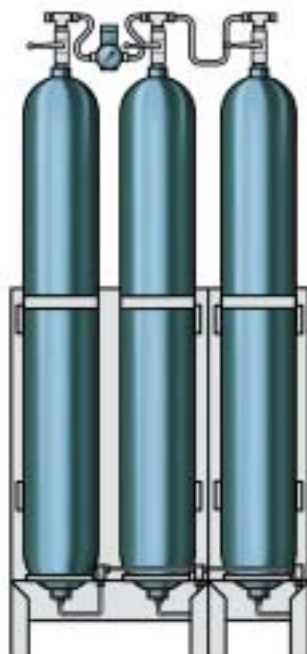

BAUER COMPRESSOR TECHNOLOGY

SAFE AND ECONOMICAL

Simple operation and low maintenance costs can only be achieved through intelligent unit design.

The engineering team at the BAUER Research and Development Center strive to ensure that BAUER keeps at the forefront of technology. Our product portfolio includes a complete range of machines to suit standard applications and is complimented by our ability to design and construct special compressor units for customer defined applications.



Automatic Condensate Drains

Maximum Space Saving

through Compact Design

All BAUER components are mounted on a common base frame and arranged with forethought and care to ensure space saving is at a premium.

Smooth Unit Running

for maximum machine life

Considerable time and engineering goes into the design of the generously dimensioned shock absorbers and rigid base frames fitted to BAUER Compressors to guarantee the best possible isolation of vibration. This minimizes the effect on the environment and assures maximum machine life with greatly reduced stresses on component parts.



I 25.0 Super Silent -unit

Total control

with COMP-TRONIC

The **BAUER COMP-TRONIC** with **clear display** controls the compressor, the motor as well as the automatic condensate drain.

The clear display **informs** the operator **at any time** about all important parameters such as oil, final temperature and maintenance work due.

Pressure and temperature **monitoring** of each stage ensure **maximum operating safety**.



Uncompromised Quality

through perfect control

BAUER ensures **maximum quality** by extensive quality assurance **monitoring during production** according to the requirements defined in **DIN EN ISO 9001**.

Each single compressor block is tested in a **continuous test run**.

The **final unit test** is done under **real operating conditions**.

Each compressor unit undergoes an **extensive function- and safety test**.

All units are **built to satisfy customer requirements**.

Simple Operation

saves Money

The principles behind the design of BAUER compressor units are Logic and Simplicity. **Ease of maintenance, best access and user friendliness** are all **integral** to the **machine design** and are not coincidental or after-thought.

In this modern world, **time is valuable**.

Simple operation, simple maintenance and easy adaptation to special requirements **saves time and saves money**.



Pressure Sensor

Ready to use

with turn-key systems

BAUER compressor units are **delivered** to the customer completely **pretested** and **ready for operation**.

This guarantees a **quick, simple** and **safe** commissioning.



COMP-TRONIC-control

THE BAUER COMPRESSOR BLOCK

EVERY UNIT HAS A STRONG HEART BEATING WITHIN

More than 50 years of experience and the knowledge in our Research and Development Center are devoted to each BAUER compressor block.

BAUER compressor blocks have a **legendary world wide reputation** for excellence due to their **reliability** and **durability**.

Our **reputation** has been **well earned** through considerable time and **effort spent on the development** of our machines with **intelligent detailed solutions** and the use of **highest quality materials** combined with **uncompromised manufacturing quality**.



Cylinders with extreme stability

Made for highest **durability**

The **bearings** in the **BAUER Compressor** are designed and constructed for a working life of **more than 30.000 operating hours**.



A cool solution

Designed for **continuous**

operation

The **intelligent cooling system** with over-sized coolers combined with large-surface ribbed cylinders ensure **optimum cooling** of each compression stage.

An **efficient forced feed lubrication system** with an oil micro filter guarantees **minimum of wear** of all moving parts.

Operating **safety**

for sure

Full stroke safety valves after each stage of compression protect the block and the system to **provide maximum safety**.

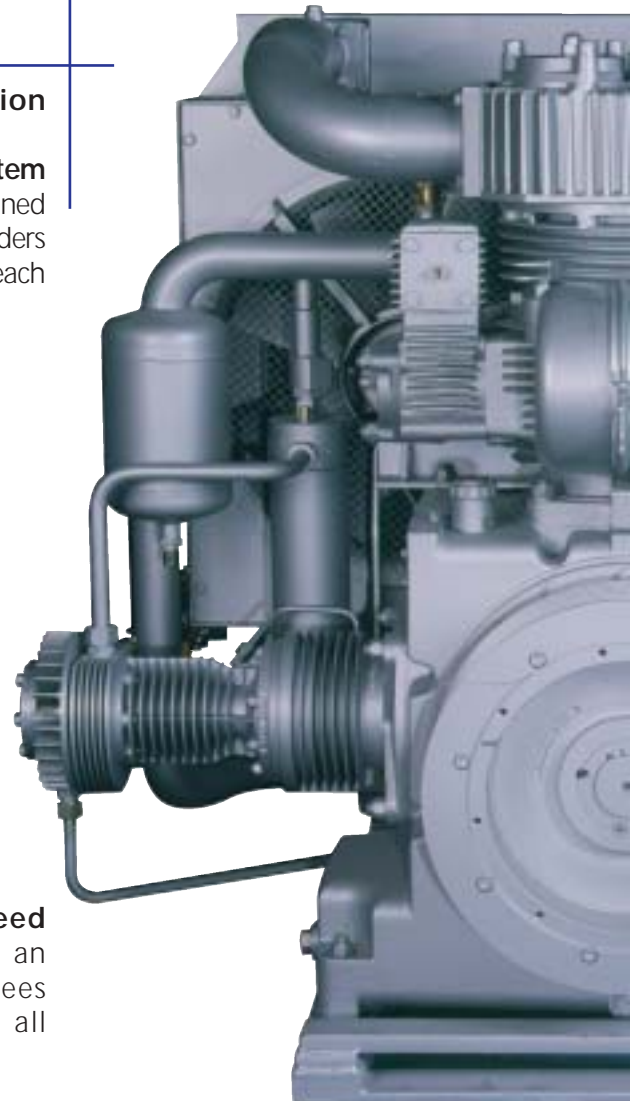

KB 60

High
efficiency

guaranteed

Optimized cylinder design and gas flow characteristics provide the BAUER Compressor with absolute **maximum performance** at **minimum power consumption**. Best efficiency through better design.

Low
costs

for maintenance and operation

Long maintenance intervals for valve checking and oil change (every 2000 operating hours) as well as piston ring check (every 3000 operating hours) **keep the operating costs** for the unit **at a minimum**.



K 22 Range

Trimmed for
quiet

running

All driving gears are **dynamically balanced** for a smooth and **vibration-free running**.

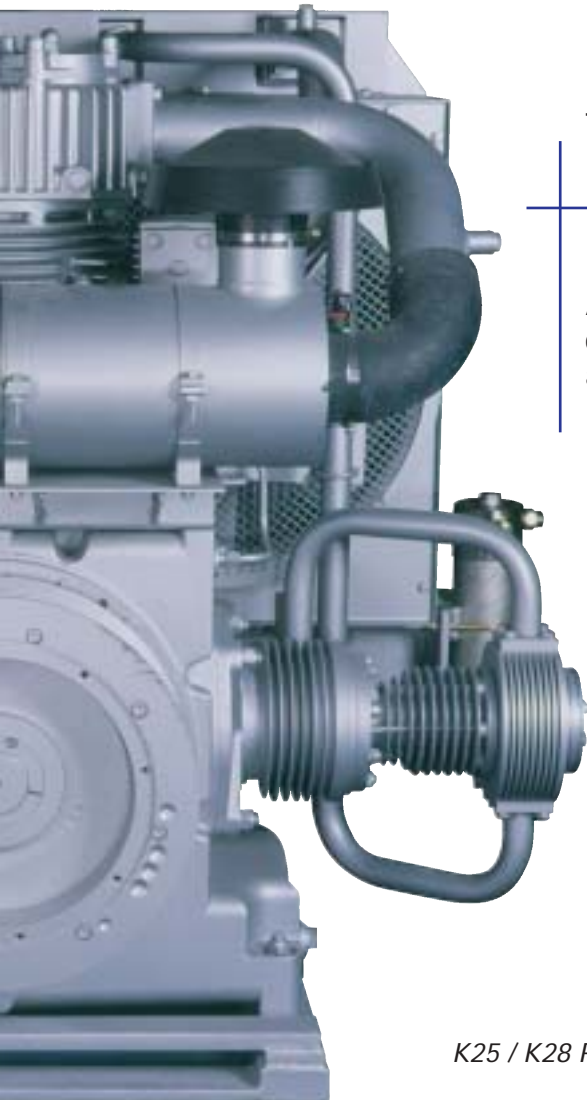

K25 / K28 Range



K 23 Range

OUR PRODUCT RANGE

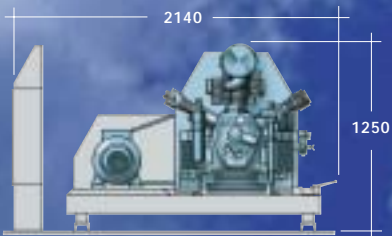
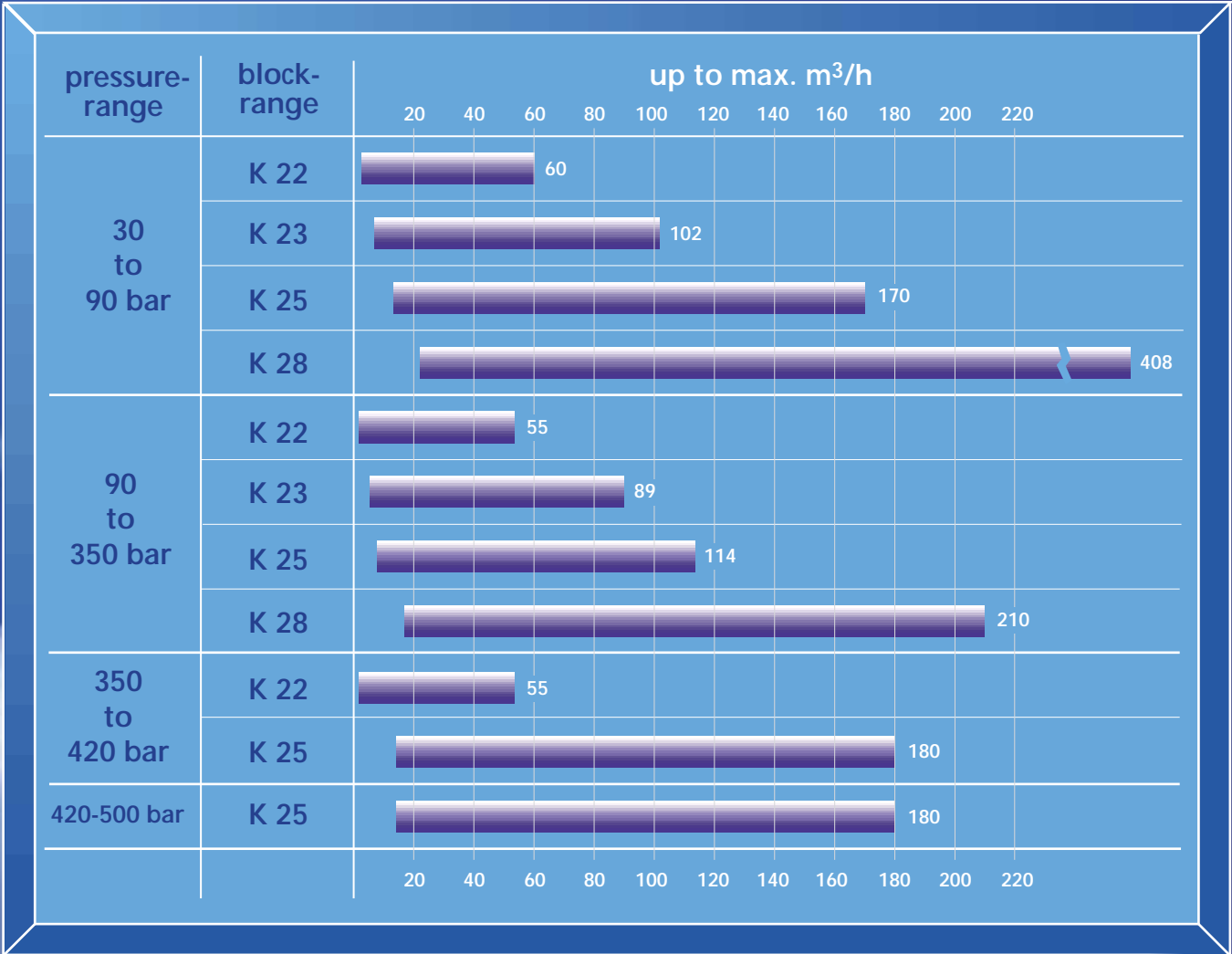

block range K22

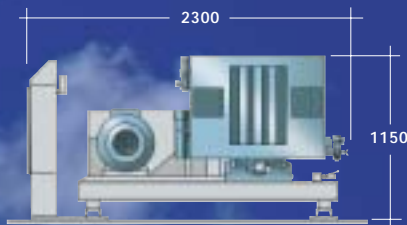

block range K23

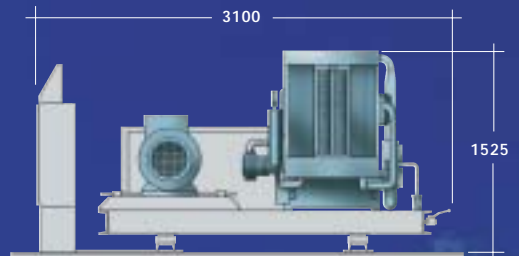

block range K25 / K28



SYSTAG

www.systag.com.au

TEL: +61 7 3206 0408

FAX: +61 7 3206 0684

EMAIL: sales@systag.com.au

ADDRESS: 112 Winston Rd, Sheldon QLD 4157

POST: P.O BOX 985, Capalaba QLD 4157